

Allgemeine technische Daten

Kolbenstange: geschliffen, poliert und hartverchromt
 Betriebstemperatur: -30° C bis +80°C
 Betriebsmittel: Hydrauliköl auf Mineralölbasis
 Anschlüsse: für Rohrverschraubungen nach DIN 2353
 Max. Betriebsdruck: 210 bar

Bestellbezeichnung (Beispiel)

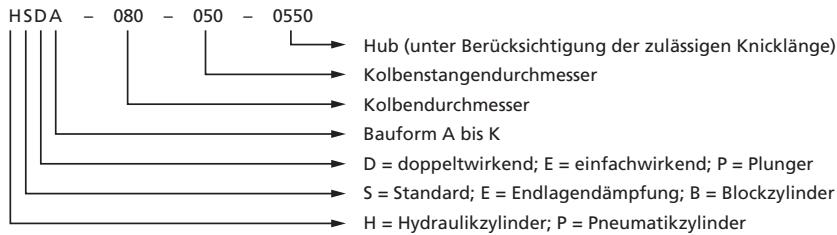

Lotz Hydraulik + Pneumatik GmbH

Denzlingerstrasse 32

79312 Emmendingen

E-Mail: info@lotz-hydraulik.de

www.lotz-hydraulik.de

Abweichende Parameter, Sonderausstattung, Normzylinder sowie Beschichtungen der Zylinder können wir Ihnen gerne auf Anfrage anbieten.

Bauform A: Grundauführung ohne Befestigung

Kolben	Kolbenstange	d ₁	a	r	c	d	e	f	F _{Zug}	F _{Druck}
25	16	35	130	G 1/4	25	42	105	25	5,80 kN	9,82 kN
32	20	42	130	G 1/4	25	42	105	25	9,80 kN	16,08 kN
35	20	45	135	G 1/4	25	42	110	25	12,96 kN	19,24 kN
40	20 (22,25,30)	50	135	G 1/4	25	42	110	25	18,85 kN	25,13 kN
50	25 (30,35)	60	142	G 3/8	25	45	117	30	29,45 kN	39,27 kN
60	25 (30,35,40)	70	162	G 3/8	25	52	137	32	46,73 kN	56,55 kN
65	30 (35,40,45)	75	162	G 1/2	25	52	137	32	52,25 kN	66,37 kN
70	40 (45,50)	80	162	G 1/2	25	52	137	32	51,84 kN	76,97 kN
80	40 (45,50,55)	90, 95	166	G 1/2	25	65	141	37	75,40 kN	100,53 kN
90	40 (45,50,55)	105	185	G 1/2	25	62	160	45	102,10 kN	127,23 kN
100	50 (60,70)	115, 120	212	G 3/4	25	72	187	45	117,81 kN	157,08 kN

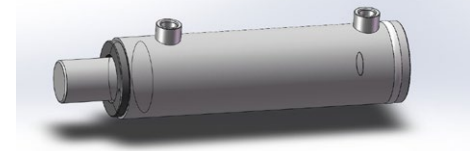
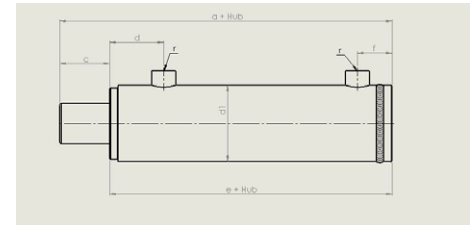

Bauform B: Schwenkauge beidseitig

Kolben	Kolbenstange	d ₁	b	a	r	d	f	i	k	F _{Zug}	F _{Druck}
25	16	35	30	145	G 1/4	42	35	8	12	5,80 kN	9,82 kN
32	20	42	30	150	G 1/4	42	40	12	20	9,80 kN	16,08 kN
35	20	45	30	155	G 1/4	42	40	12	20	12,96 kN	19,24 kN
40	25 (30)	50	30	150	G 1/4	42	40	12	20	15,32 kN	25,13 kN
50	30 (35)	60	35	168	G 3/8	45	45	15,20	20	25,13 kN	39,27 kN
60	30 (35,40)	70	35	185	G 3/8	52	45	20,25	25	42,41 kN	56,55 kN
65	30 (35,40,45)	75	40	200	G 1/2	52	50	20,25	25	52,23 kN	66,37 kN
70	40 (45,50)	80	40	200	G 1/2	52	50	25	30	51,84 kN	76,97 kN
80	40 (45,50,55)	90, 95	40	209	G 1/2	65	50	30	30	75,40 kN	100,53 kN
90	40 (45,50,55)	105	40	225	G 1/2	62	65	30	30	102,10 kN	127,23 kN
100	50 (60,70)	115, 120	50	272	G 3/4	72	70	30	40	117,81 kN	157,08 kN

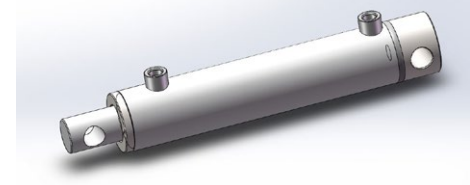
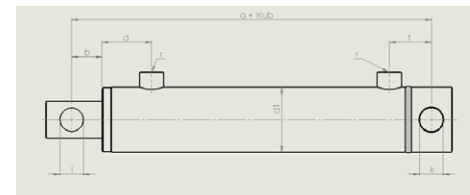

Bauform C: Schwenkauge beidseitig

Kolben	Kolbenstange	d ₁	b	a	r	c	d	e	f	i	k	F _{Zug}	F _{Druck}
25	16	35	50	205	G 1/4	25	42	105	25	15	12	5,80 kN	9,82 kN
32	20	42	55	215	G 1/4	25	42	105	25	20	20	9,80 kN	16,08 kN
35	20	45	55	220	G 1/4	25	42	110	25	20	20	12,96 kN	19,24 kN
40	20 (22,25,30)	50	55	220	G 1/4	25	42	110	25	20	20	18,85 kN	25,13 kN
50	25 (30,35)	60	60	237	G 3/8	25	45	117	30	20	25	29,45 kN	39,27 kN
60	25 (30,35,40)	70	60	257	G 3/8	25	52	137	32	25	25	46,73 kN	56,55 kN
65	30 (35,40,45)	75	65	267	G 1/2	25	52	137	32	25	30	52,23 kN	66,37 kN
70	40 (45,50)	80	65	267	G 1/2	25	52	137	32	25	30	51,84 kN	76,97 kN
80	40 (45,50,55)	90, 95	65	271	G 1/2	25	65	141	37	30	30	75,40 kN	100,53 kN
90	40 (45,50,55)	105	70	295	G 1/2	25	62	160	45	40	35	102,10 kN	127,23 kN
100	50 (60,70)	115, 120	75	337	G 3/4	25	72	187	45	40	40	117,81 kN	157,08 kN

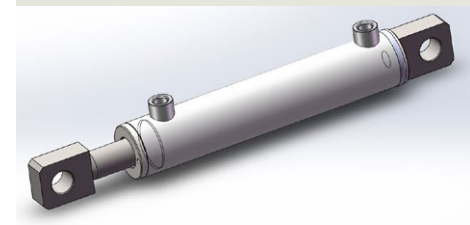
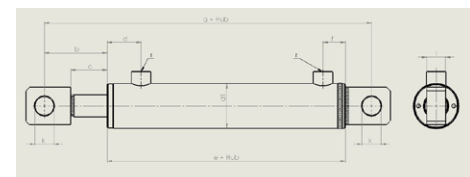

Bauform D: Gelenkauge am Zylinderboden

Kolben	Kolbenstange	d ₁	d ₂	b	a	r	c	d	e	f	g	h	i	k	F _{Zug}	F _{Druck}
35	20	45	M16x1,5	16	168	G 1/4	20	42	110	25	38	19	16	20	12,96 kN	19,24 kN
40	20 (22,25,30)	50	M16x1,5	16	168	G 1/4	20	42	110	25	38	19	16	20	18,85 kN	25,13 kN
50	25 (30,35)	60	M16x1,5	16	182	G 3/8	20	45	117	30	45	23	20	25	29,45 kN	39,27 kN
60	25 (30,35,40)	70	M22x1,5	22	208	G 3/8	20	52	137	32	51	28	22	30	46,73 kN	56,55 kN
65	30 (35,40,45)	75	M22x1,5	22	208	G 1/2	20	52	137	32	51	28	22	30	52,23 kN	66,37 kN
70	40 (45,50)	80	M28x1,5	28	218	G 1/2	20	52	137	32	61	30	25	35	51,84 kN	76,97 kN
80	40 (45,50,55)	90, 95	M35x1,5	35	235	G 1/2	25	65	141	37	69	35	28	40	75,40 kN	100,53 kN
90	40 (45,50,55)	105	M35x1,5	35	254	G 1/2	25	62	160	45	69	35	28	40	102,13 kN	127,23 kN
100	50 (60,70)	115, 120	M45x1,5	45	300	G 3/4	25	72	187	45	88	40	35	50	117,81 kN	157,08 kN

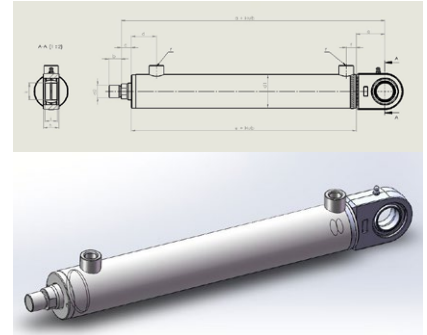

Bauform E: Gelenkauge am Zylinderboden

Kolben	Kolbenstange	d ₁	d ₂	b	a	r	c	d	e	f	g	i	k	F _{Zug}	F _{Druck}
25	16	35	M14	20	156	G 1/4	20	42	105	25	31	12	15	5,80 kN	9,82 kN
32	20	42	M16	20	160	G 1/4	20	42	105	25	35	14	17	9,80 kN	16,08 kN
35	20	45	M16x1,5	16	168	G 1/4	20	42	110	25	38	16	20	12,96 kN	19,24 kN
40	20 (22,25,30)	50	M16x1,5	16	168	G 1/4	20	42	110	25	38	16	20	18,85 kN	25,13 kN
50	25 (30,35)	60	M16x1,5	16	182	G 3/8	20	45	117	30	45	20	25	29,45 kN	39,27 kN
60	25 (30,35,40)	70	M22x1,5	22	208	G 3/8	20	52	137	32	51	22	30	46,73 kN	56,55 kN
65	30 (35,40,45)	75	M22x1,5	22	208	G 1/2	20	52	137	32	51	22	30	52,23 kN	66,37 kN
70	40 (45,50)	80	M28x1,5	28	218	G 1/2	20	52	137	32	61	25	35	51,48 kN	76,97 kN
80	40 (45,50,55)	90, 95	M35x1,5	35	235	G 1/2	25	65	141	37	69	28	40	75,40 kN	100,53 kN
90	40 (45,50,55)	105	M35x1,5	35	254	G 1/2	25	62	160	45	69	28	40	102,10 kN	127,23 kN
100	50 (60,70)	115, 120	M45x1,5	45	300	G 3/4	25	72	187	45	88	35	50	117,81 kN	157,08 kN

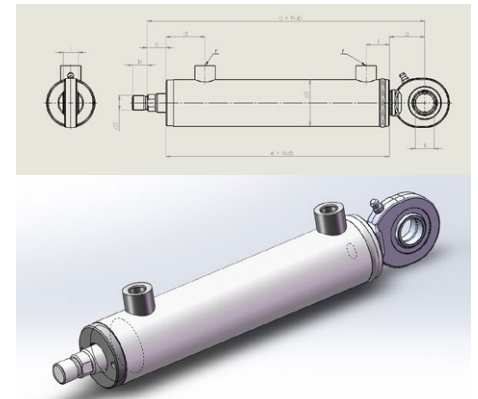

Bauform F: Gelenkauge beidseitig

Kolben	Kolbenstange	d ₁	b	a	r	c	d	e	f	i	k	F _{Zug}	F _{Druck}
25	16	35	192	G 1/4	56	42	105	25	31	12	15	5,80 kN	9,82 kN
32	20	42	200	G 1/4	60	42	105	25	35	14	17	9,80 kN	16,08 kN
35	20	45	211	G 1/4	63	42	110	25	38	16	20	12,96 kN	19,24 kN
40	20 (22,25,30)	50	211	G 1/4	63	42	110	25	38	16	20	18,85 kN	25,13 kN
50	25 (30,35)	60	232	G 3/8	70	45	117	30	45	20	25	29,45 kN	39,27 kN
60	25 (30,35,40)	70	264	G 3/8	76	52	137	32	51	22	30	46,73 kN	56,55 kN
65	30 (35,40,45)	75	264	G 1/2	76	52	137	32	51	22	30	52,23 kN	66,37 kN
70	40 (45,50)	80	284	G 1/2	86	52	137	32	61	25	35	51,84 kN	76,97 kN
80	40 (45,50,55)	90, 95	304	G 1/2	94	65	141	37	69	28	40	75,40 kN	100,53 kN
90	40 (45,50,55)	105	323	G 1/2	94	62	160	45	69	28	40	102,10 kN	127,23 kN
100	50 (60,70)	115, 120	388	G 3/4	113	72	187	45	88	35	50	117,81 kN	157,08 kN

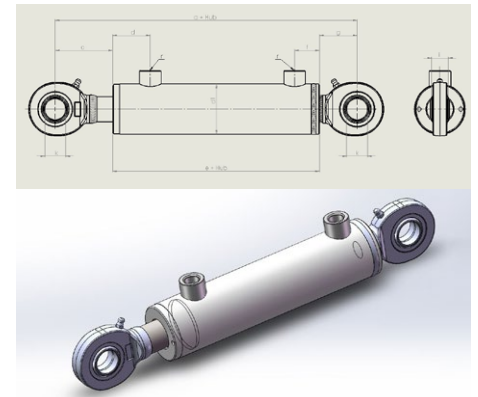

Bauform G: Fußbefestigung

Kolben	Kolbenstange	d ₁	d ₂	b	a	r	c	d	e	f	g	h	i	k	m	F _{Zug}	F _{Druck}
25	16	35	M14	20	125	G 1/4	20	42	105	25	50	nach Kundenwunsch	45	15	9	5,80 kN	9,82 kN
32	20	42	M16	20	125	G 1/4	20	42	105	25	65		80	15	11	9,80 kN	16,08 kN
35	20	45	M16x1,5	16	130	G 1/4	20	42	110	25	65		80	15	11	12,96 kN	19,24 kN
40	20 (22,25,30)	50	M16x1,5	16	130	G 1/4	20	42	110	25	65		90	15	11	18,85 kN	25,13 kN
50	25 (30,35)	60	M16x1,5	16	137	G 3/8	20	45	117	30	65		100	20	13	29,45 kN	39,27 kN
60	25 (30,35,40)	70	M22x1,5	22	157	G 3/8	20	52	137	32	65		100	25	15	46,73 kN	56,55 kN
65	30 (35,40,45)	75	M22x1,5	22	157	G 1/2	20	52	137	32	65		120	25	15	52,23 kN	66,37 kN
70	40 (45,50)	80	M28x1,5	28	157	G 1/2	20	52	137	32	65		120	25	15	51,84 kN	76,97 kN
80	40 (45,50,55)	90, 95	M35x1,5	35	166	G 1/2	25	65	141	37	70		130	30	15	75,40 kN	100,53 kN
90	40 (45,50,55)	105	M35x1,5	35	185	G 1/2	25	62	160	45	75		140	30	18	102,10 kN	127,23 kN
100	50 (60,70)	115, 120	M45x1,5	45	212	G 3/4	25	72	187	45	75	140	30	18	117,81 kN	157,08 kN	

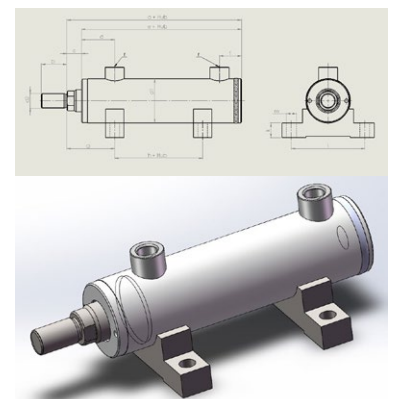

Bauform H: Schwenkzapfen

Kolben	Kolbenstange	d ₁	d ₂	b	a	r	c	d	e	f	g	h	i	k	F _{Zug}	F _{Druck}
25	16	35	M14	20	125	G 1/4	20	42	105	25	nach Kundenwunsch	85	55	15	5,80 kN	9,82 kN
32	20	42	M16	20	125	G 1/4	20	42	105	25		90	60	17	9,80 kN	16,08 kN
35	20	45	M16x1,5	16	130	G 1/4	20	42	110	25		95	65	20	12,96 kN	19,24 kN
40	20 (22,25,30)	50	M16x1,5	16	130	G 1/4	20	42	110	25		110	70	20	18,85 kN	25,13 kN
50	25 (30,35)	60	M16x1,5	16	137	G 3/8	20	45	117	30		130	80	25	29,45 kN	39,27 kN
60	25 (30,35,40)	70	M22x1,5	22	157	G 3/8	20	52	137	32		140	90	30	46,73 kN	56,55 kN
65	30 (35,40,45)	75	M22x1,5	22	157	G 1/2	20	52	137	32		145	95	30	52,23 kN	66,37 kN
70	40 (45,50)	80	M28x1,5	28	157	G 1/2	20	52	137	32		160	110	35	51,84 kN	76,97 kN
80	40 (45,50,55)	90, 95	M35x1,5	35	166	G 1/2	25	65	141	37		175	125	40	75,40 kN	100,53 kN
90	40 (45,50,55)	105	M35x1,5	35	185	G 1/2	25	62	160	45		200	140	40	102,10 kN	127,23 kN
100	50 (60,70)	115, 120	M45x1,5	45	212	G 3/4	25	72	187	45	210	150	50	117,81 kN	157,08 kN	

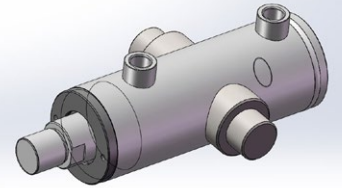
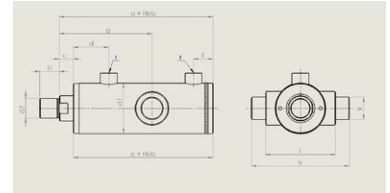

Bauform I: Mittelflansch

Kolben	Kolbenstange	d ₁	d ₂	b	a	r	c	d	e	f	g	h	i	k	d ₃	F _{Zug}	F _{Druck}
25	16	35	M14	20	125	G 1/4	20	42	105	25	50	9	nach Kundenwunsch	10	90	5,80 kN	9,82 kN
32	20	42	M16	20	125	G 1/4	20	42	105	25	65	9		10	94	9,80 kN	16,08 kN
35	20	45	M16x1,5	16	130	G 1/4	20	42	110	25	65	9		10	100	12,96 kN	19,24 kN
40	20 (22,25,30)	50	M16x1,5	16	130	G 1/4	20	42	110	25	65	11		15	104	18,85 kN	25,13 kN
50	25 (30,35)	60	M16x1,5	16	137	G 3/8	20	45	117	30	65	11		20	118	29,45 kN	39,27 kN
60	25 (30,35,40)	70	M22x1,5	22	157	G 3/8	20	52	137	32	65	13		20	138	46,73 kN	56,55 kN
65	30 (35,40,45)	75	M22x1,5	22	157	G 1/2	20	52	137	32	65	13		20	150	52,23 kN	66,37 kN
70	40 (45,50)	80	M28x1,5	28	157	G 1/2	20	52	137	32	65	15		25	160	51,84 kN	76,97 kN
80	40 (45,50,55)	90, 95	M35x1,5	35	166	G 1/2	25	65	141	37	70	17		25	178	75,40 kN	100,53 kN
90	40 (45,50,55)	105	M35x1,5	35	185	G 1/2	25	62	160	45	75	17		25	190	102,10 kN	127,23 kN
100	50 (60,70)	115, 120	M45x1,5	45	212	G 3/4	25	72	187	45	75	17	30	245	117,81 kN	157,08 kN	

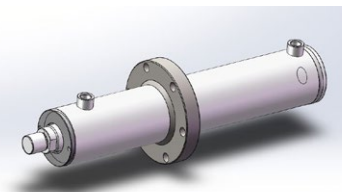
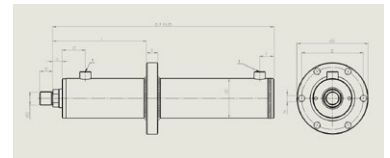

Bauform J: Kopfflansch

Kolben	Kolbenstange	d ₁	d ₂	b	a	r	c	d	e	f	d ₃	g	h	i	k	d ₄	F _{Zug}	F _{Druck}
25	16	35	M14	20	145	G 1/4	20	42	125	25	90	70	9	8	10	34	5,80 kN	9,82 kN
32	20	42	M16	20	145	G 1/4	20	42	125	25	94	75	9	8	10	40	9,80 kN	16,08 kN
35	20	45	M16x1,5	16	150	G 1/4	20	42	130	25	100	80	9	8	10	45	12,96 kN	19,24 kN
40	20 (22,25,30)	50	M16x1,5	16	150	G 1/4	20	42	130	25	104	85	11	8	15	50	18,85 kN	25,13 kN
50	25 (30,35)	60	M16x1,5	16	157	G 3/8	20	45	137	30	118	95	11	10	20	60	29,45 kN	39,27 kN
60	25 (30,35,40)	70	M22x1,5	22	177	G 3/8	20	52	157	32	138	115	13	10	20	70	46,73 kN	56,55 kN
65	30 (35,40,45)	75	M22x1,5	22	177	G 1/2	20	52	157	32	150	125	13	10	20	75	52,23 kN	66,37 kN
70	40 (45,50)	80	M28x1,5	28	177	G 1/2	20	52	160	32	160	135	15	10	25	80	51,84 kN	76,97 kN
80	40 (45,50,55)	90, 95	M35x1,5	35	186	G 1/2	25	65	169	37	178	145	17	10	25	89	75,40 kN	100,53 kN
90	40 (45,50,55)	105	M35x1,5	35	205	G 1/2	25	62	185	45	190	165	17	10	25	105	102,10 kN	127,23 kN
100	50 (60,70)	115, 120	M45x1,5	45	242	G 3/4	25	72	227	45	245	205	17	12	30	115	117,81 kN	157,08 kN

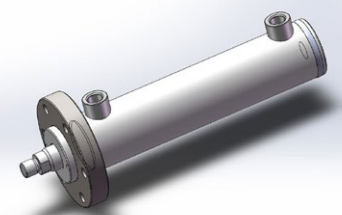
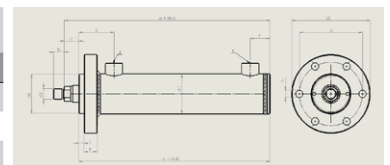

Bauform K: Fußflansch

Kolben	Kolbenstange	d ₁	d ₂	b	a	r	c	d	e	f	d ₃	g	h	k	F _{Zug}	F _{Druck}
25	16	35	M14	20	135	G 1/4	20	42	115	23	90	70	9	10	5,80 kN	9,82 kN
32	20	42	M16	20	135	G 1/4	20	42	115	23	94	75	9	10	9,8 kN	16,08 kN
35	20	45	M16x1,5	16	140	G 1/4	20	42	120	23	100	80	9	10	12,96 kN	19,24 kN
40	20 (22,25,30)	50	M16x1,5	16	145	G 1/4	20	42	125	23	104	85	11	15	18,85 kN	25,13 kN
50	25 (30,35)	60	M16x1,5	16	157	G 3/8	20	45	137	28	118	95	11	20	29,45 kN	39,27 kN
60	25 (30,35,40)	70	M22x1,5	22	177	G 3/8	20	52	157	30	138	115	13	20	46,73 kN	56,55 kN
65	30 (35,40,45)	75	M22x1,5	22	177	G 1/2	20	52	157	30	150	125	13	20	52,23 kN	66,37 kN
70	40 (45,50)	80	M28x1,5	28	182	G 1/2	20	52	162	30	160	135	15	25	51,84 kN	76,97 kN
80	40 (45,50,55)	90, 95	M35x1,5	35	191	G 1/2	25	65	166	35	178	145	17	25	75,40 kN	100,53 kN
90	40 (45,50,55)	105	M35x1,5	35	210	G 1/2	25	62	185	43	190	165	17	25	102,10 kN	127,23 kN
100	50 (60,70)	115, 120	M45x1,5	45	242	G 3/4	25	72	217	43	245	205	17	30	117,81 kN	157,08 kN

